

© Copyright Xandex Inc., All Rights Reserved. The information disclosed herein is deemed to be confidential, proprietary, and a trade secret of Xandex, Inc. This information may not be used, reproduced or disclosed without the expressed prior written consent of Xandex, Inc.

REVISIONS

REV	DESCRIPTION	CHANGE NUMBER	BY	DATE	APPROVED
A	INITIAL RELEASE	4526	MRW	05/16/22	

NOTES:

- SHUTTLE ASSEMBLY PART NUMBER IS 316-0010 OR 316-0012.
- DIMENSIONS SHOWN REPRESENT THE SHUTTLE WITH A DM-2 CARTRIDGE INSTALLED.
- ALL DIMENSIONS SHOWN IN EXTENDED POSITION AS IT DEPOSITS INK ON THE WAFER.
- SHUTTLE MOUNTS USING (2) 1-72 SOCKET HEAD CAP SCREWS.
- SHUTTLE TRAVELS APPROXIMATELY .050 FROM RETRACTED POSITION TO DEPOSIT INK ONTO THE WAFER SURFACE.
- THE 2.18 TO 2.21 SHIFT CAN BE RESOLVED IN INKER BASE Z-ADJUSTMENT.
- THE WEIGHT OF THE ASSEMBLY HAS INCREASED 8 GRAMS.

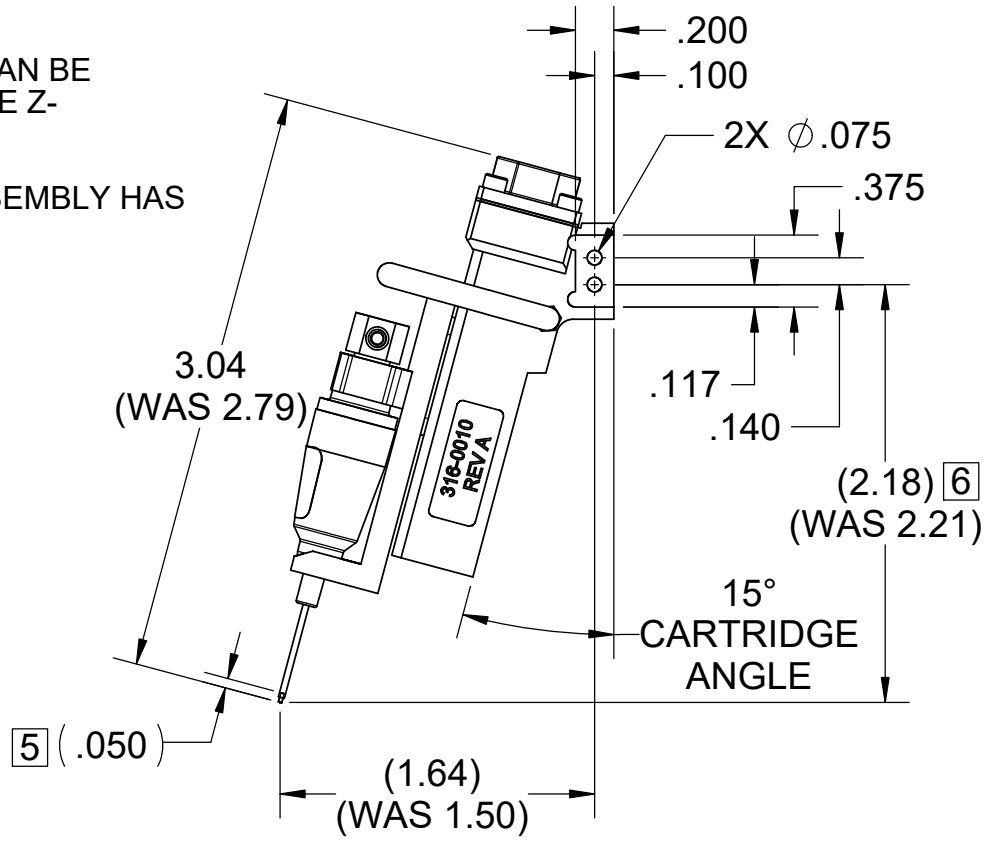
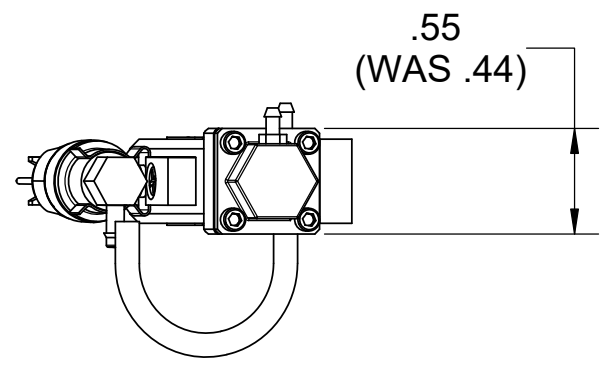

APPROVALS	DATE
DRAWN	MRW 11/2/2021
CHECKED	File Approved per DCA#147
ENGRG	J. THOMAS 11/2/2021
NEXT ASSEMBLIES.....USED ON	
THIRD ANGLE PROJECTION	

INTERPRET DRAWING PER ASME Y14.5M-1994

TOLERANCES UNLESS OTHERWISE SPECIFIED DIMENSIONS ARE IN INCHES

DECIMALS 1 PL ±.1  
2 PL ±.01  
3 PL ±.005

FRACTIONS ±  
ANGLES ± 1°

63 ALL SURFACES

**XANDEX INC.** 1360 REDWOOD WAY, SUITE A  
PETALUMA, CA 94954  
(707) 763-7799

TITLE  
**OD DWG PREC PNEU SHUTTLE - X1100 SERIES**

DO NOT SCALE DRAWING

SIZE	SCALE	SHEET	DRAWING NUMBER	REV
<b>A</b>	<b>1:1</b>	<b>1 OF 1</b>	<b>900-0219</b>	<b>A</b>