



## Product/Process Change Notification

<b>PCN Number:</b>	100018-A	<b>Product Category:</b>	Inker Hardware	<b>Issue Date:</b>	9-Nov-15
<b>Contact:</b>	Inside Sales	E-Mail: insidesales@xandex.com			
	1360 Redwood Way, Suite A	Phone: 707-763-7799			
	Petaluma, CA 94954	Fax: 707-763-2631			
<b>Description of Change to Customer:</b>					
Actuator mechanism redesigned to reduce the force required to actuate.					
<b>Reason For Change:</b>					
Improve reliability and increase period between required Preventative Maintenance actions.					
<b>Customer Impact of Change and Recommended Action:</b>					
Verify actuator mechanism does not impact specific customer use model.					
<b>Forecasted Key Milestones:</b> Subject to change based on business conditions					<b>Date:</b>
<b>Complete Internal Qualification Testing</b>					Complete
<b>Samples Available To Order</b>					Now
<b>First Shipment of Changed Product</b> (as early as)					9-Feb-16
<b>Last Shipment of Unchanged Product</b> (subject to material availability)					8-Feb-16
<b>Method of Identifying Changed Product:</b>					
Visually different (see accompanying pictures)					
<b>Assessment:</b>					
Change in function (actuation time), form (see accompanying pictures)					
<b>Products and Xandex Part Numbers Affected</b>					
Retrofit Cartridge Holder      315-0008   315-0010   315-0011					
<b>Revision History</b>					
<b>Date of Revision:</b>	<b>Revision Letter:</b>	<b>Reason:</b>			
9-Nov-15	A	Initial publication			

Please contact your Xandex sales representative for any questions or support requirements. Please return any response as soon as possible, but not to exceed 30 days.

### PCN100018-A Appendix: Qualification Testing

Test	Result
Design Verification Testing	Pass
Ink Dot Testing	Pass

PCN #100018

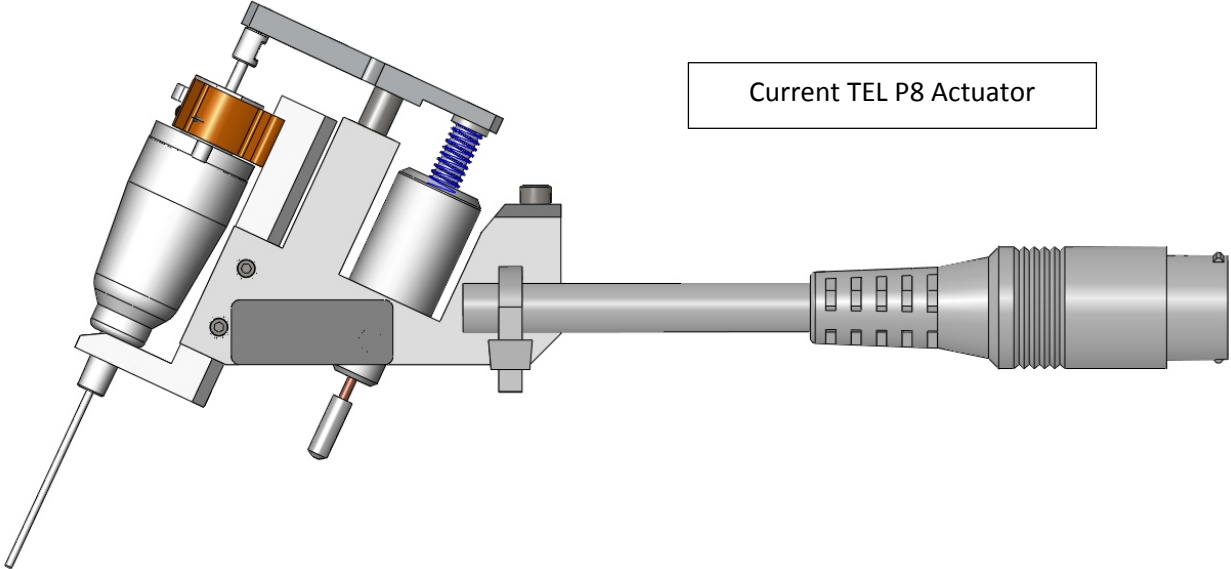

Current TEL P8 Actuator

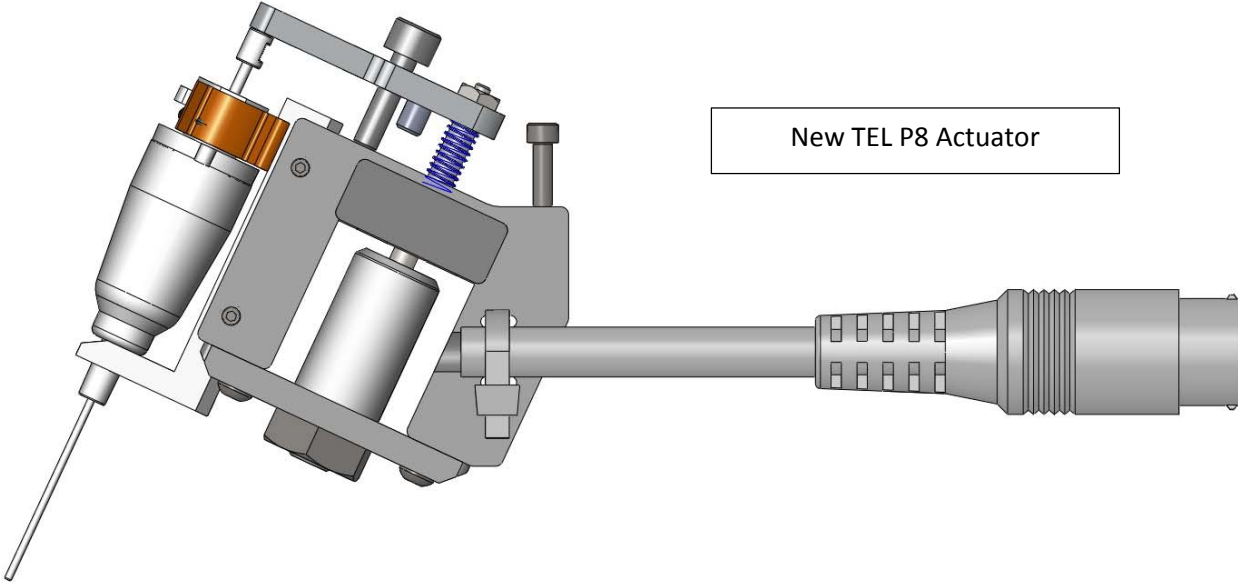

New TEL P8 Actuator